

Ref. : VPN 3448-02 pas

Rev. : D

Date : 04/11/2014

Page : 1/1

BUTTERFLY VALVE WITH HANDLE

VPN 3448-02



APPLICATION

General use : water, air, acids etc...

CARACTERISTIQUES GENERALES

Design according with BS EN 593.
 Type with lugs, tightness in both ways.
 Sleeve in dovetail shape ensures a perfect assembling (for high vacuum we can stick it).
 High and low semi stem giving a high flow coefficient, machined disc on periphery giving a low and regular torque.
 Unejectable stem, dovetail type sleeve, mouting flange according to ISO 5211.
 Ductile iron handle ensures 10 locked notched positions, ensures fine regulation.



CONSTRUCTION

16	1	Screw	Stainless steel A2	
15	2	Washer	Stainless steel A2	
14	2	Nut	Stainless steel A2	
13	2	Screw	Stainless steel A2	
12	1	Handle	Ductile iron	
11	1	Nameplate	Stainless steel 304	
10	2	Circlip	Steel	
9	1	Bottom cover	PE	
8	2	O ring	EPDM	
7	1	Antidust ring	NBR	
6	1	Anti blowout ring	Stainless steel 420	DIN : 1.4021 ASTM : AISI 420 BS : 420 S 37
5	1	Upper stem	Stainless steel 420	DIN : 1.4021 ASTM : AISI 420 BS : 420 S 37
4	1	Lower stem	Stainless steel 420	DIN : 1.4021 ASTM : AISI 420 BS : 420 S 37
3	1	Sleeve	EPDM CH	In standard
2	1	Disc	Ductile iron EN-GJS-400-15	DIN: GGG 40 ASTM: A536 65-45-12 BS: 1563 EN-JS1030
1	1	Body	EN-GJL-250	DIN : GG25 ASTM : A48 class 40B BS : 1452 Grade 250
Pos.	Qty	Description	Material	

DIMENSIONS

DN		A	B	C	G	V	Weight (kg)
mm	inch						
40**	1 1/2	134	58	34	52,5	180	2,05
50	2"	139,7	65	41,8	52,5	180	2,52
65	2 1/2	152,4	73	45,3	52,5	180	2,99
80	3"	158,8	85	45,3	52,5	180	3,43
100	4"	178	100	51,5	52,5	180	4,33
125	5"	190,5	115	54,5	58	220	6,58
150	6"	203	120	54,5	58	220	7,52
200	8"	238	160	59,6	65	450	14,3
250	10"	268,3	195	68	65	450	21,5
300	12"	306,4	230	78	65	450	30,5

** Can be installed between DN32 flanges

WORKING CONDITIONS

Maximum working pressure : 16 bar.
 Maximum working temperature : -15°C / +130°C.
 Peak temperature: -30°C / +150°C

Sleeve types in option	Maximum temperature	Peak temperature
EPDM	+ 4°C / + 110°C	- 20°C / +130°C
White EPDM	+ 4°C / + 110°C	- 20°C / +130°C
CSM (Type Hypalon®)	+ 4°C / +80°C	- 20°C / +110°C
FPM (Type Viton®)	- 10°C / +170°C	- 20°C / +200°C
Silicone	- 20°C / +170°C	- 40°C / +200°C
Nitril (NBR)	- 10°C / +80°C	- 20°C / +90°C

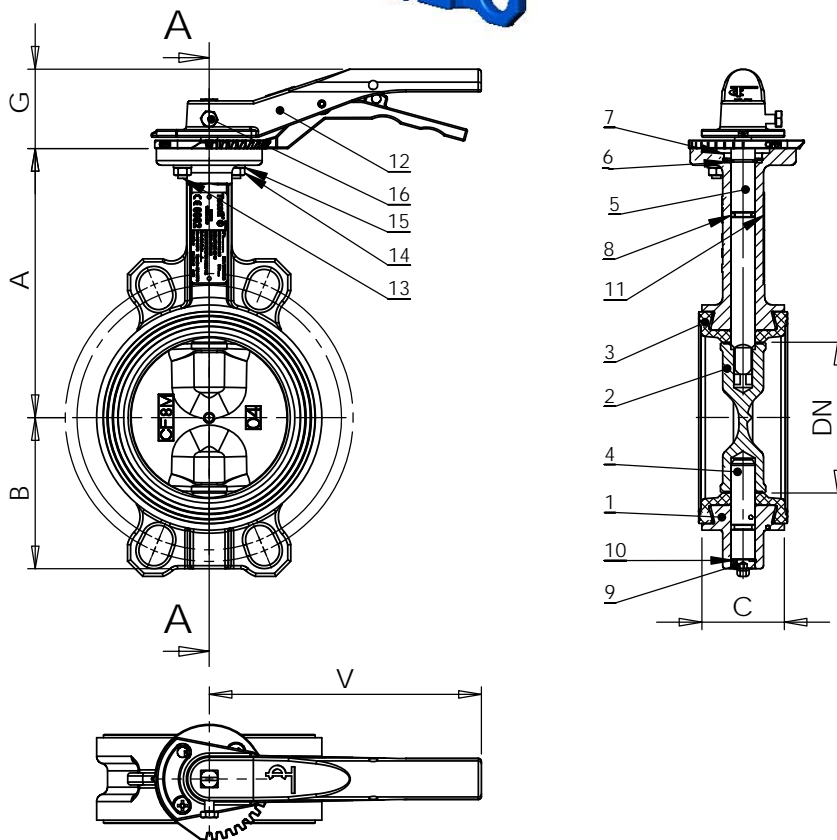

STANDARDS

Manufacture according to the requirements of the European directive 97/23/CE «Equipment under pressure»: modulate H.
 Face to face according to standards NF EN 558-1 serie 20, ISO 5272 série 20, DIN 3202.
 Mounting between flanges PN 10 / PN 16: according to EN 1092-2, BS 450, ANSI B16.1-5.
 Adjustable between flanges ASME B16.5 Class 150 and JIS 10K.
 Pressure test according to standards EN 12266-1, DIN 3230, BS 6755 and ISO 5208 :
 Corps: 24 bar
 Siège: 17.6 bar

TECOFI France - 83, Rue Marcel Mérieux 69960 Corbas - France
 Tél. +33 (0)4 72 79 05 79 - Fax +33 (0)4 78 90 19 19 / +33 (0)4 72 79 05 79
 Adresses e-mail: sales@tecofi.fr; tecofi@tecofi.fr / site web: www.tecofi.fr